

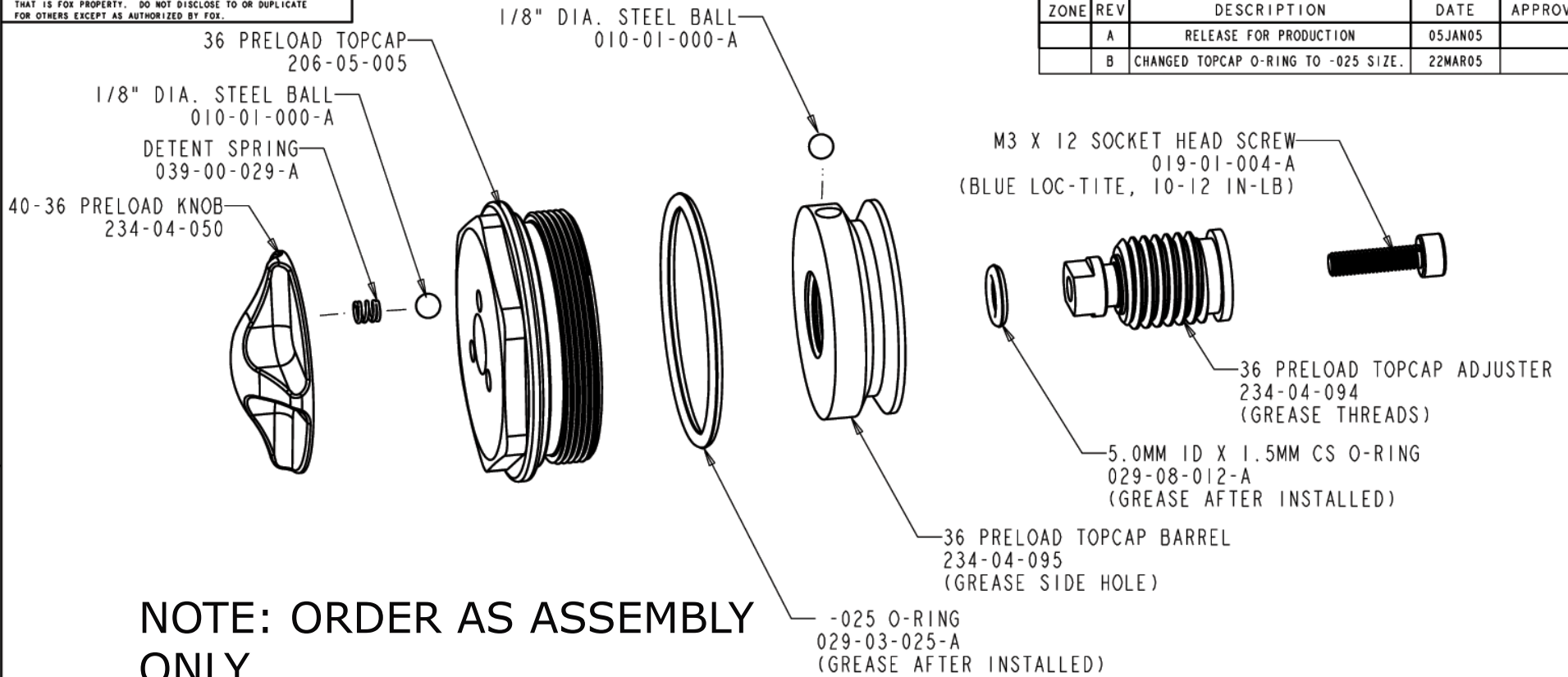

— PROPRIETARY —
 THIS DOCUMENT CONTAINS CONFIDENTIAL, PROPRIETARY INFORMATION
 THAT IS FOX PROPERTY. DO NOT DISCLOSE TO OR DUPLICATE
 FOR OTHERS EXCEPT AS AUTHORIZED BY FOX.

REVISIONS				
ZONE	REV	DESCRIPTION	DATE	APPROVED
	A	RELEASE FOR PRODUCTION	05JAN05	
	B	CHANGED TOPCAP O-RING TO -.025 SIZE.	22MAR05	

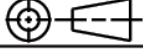

NOTE: ORDER AS ASSEMBLY ONLY.

ITEM NO.	QTY.	PART NUMBER	DESCRIPTION	MATERIAL SPEC
UNLESS OTHERWISE SPECIFIED DIMENSIONS ARE IN INCHES			PER ANSI Y14.5M 1994	
TOLERANCES ARE:			 FOX Factory, Inc. 130 Hongor Way, Watsonville, CA 94076 USA, Ph 831-768-1100, Fax 831-768-9312	
DECIMALS .XX ± .01			APPROVALS	DATE
ANGLES ± 1°			DWN. BY B. BECKER	05JAN05
.XXX ± .005			CHK. BY B. BECKER	05JAN05
THIRD ANGLE PROJECTION			ENG. B. BECKER	05JAN05
			MFG.	SIZE B
DO NOT SCALE DRAWING			ADD.	PART NO. 820-05-024
			PLOT SCALE 2:1	SHEET 1 OF 2