

— PROPRIETARY —
 THIS DOCUMENT CONTAINS CONFIDENTIAL, PROPRIETARY INFORMATION
 THAT IS FOX PROPERTY. DO NOT DISCLOSE TO OR DUPLICATE
 FOR OTHERS EXCEPT AS AUTHORIZED BY FOX.

REVISIONS				
ZONE	REV	DESCRIPTION	DATE	APPROVED
	A	RELEASE FOR PRODUCTION	12APR05	

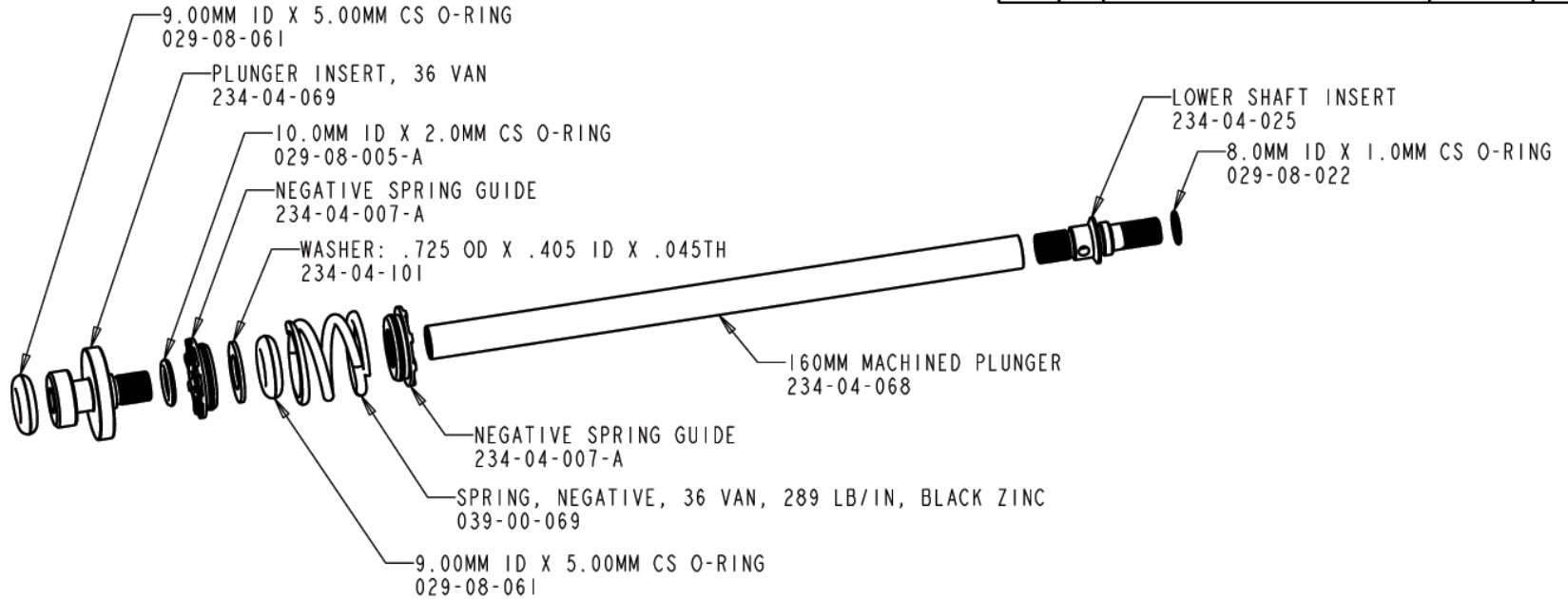
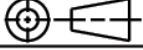

NOTE: ORDER AS COMPLETE UNIT 820-2-021

ITEM NO.	QTY.	PART NUMBER	DESCRIPTION	MATERIAL SPEC
UNLESS OTHERWISE SPECIFIED DIMENSIONS ARE IN INCHES			PER ANSI Y14.5M 1994	
TOLERANCES ARE: DECIMALS .XX ± .01 .XXX ± .005			APPROVALS DWN. BY B. LAMPMAN CHK. BY B. LAMPMAN ENG. B. LAMPMAN MFG. ADD.	DATE 11JAN05 11JAN05 11JAN05
THIRD ANGLE PROJECTION 			FOX Factory, Inc. 130 Hongor Way, Watsonville, CA 94076 USA, Ph 831-768-1100, Fax 831-768-9312	
			SIZE B	PART NO. 820-02-021
DO NOT SCALE DRAWING			PLOT SCALE 1:1	SHEET 1 OF 1